

INDEX APLIKACIJA
A
AD

AD534JH	241
AD633JN	241
AD654JN	241
AD711JN	241
AD712JN	241

AM

AM26LS31	241
AM26LS32	242

C
CA

CA3046	242
CA3059	242
CA3080E	242
CA3081	242
CA3082E	243
CA3083	243
CA3086	243
CA3096	243
CA3130E	243
CA3140E	244
CA3240E	244
CA5160	244
CA5260E	244

D
DAC

DAC0800LCN	244
DAC08CP	245

DG

DG211CJ	245
DG411	245
DG508ACJ	245

H
HA

HA12017	245
-------------------	-----

I
ICL

ICL7106CPL	246
ICL7107CPL	246
ICL7109CPL	246
ICL7116CPL	246
ICL7129CPL	246
ICL7135CPL	247
ICL7611DCPA	247
ICL7621DCPA	247
ICL7641ECPD	247
ICL7650CPD	247

ICL7660CPA	248
ICL7665CPA	248

ICM

ICM7211AIPL	248
ICM7217IJI	248
ICM7218AIJI	249
ICM7224IPL	249
ICM7226AJL	249
ICM7555IPA	249
ICM7556IPD	249
IR2110	250
IR2112	250
IR2113	250
IR2110S-SMD	250
IR2112S-SMD	250
IR2111	250
IR2117	250
IR2121	250
IR2125	250
IR2151	250
IR2153	250
IR2155	250
IR2184	250

L
L

L165	251
L272	251
L293E	251
L297	251
L298	251

LF

LF355N	252
LF411CN	252
LF412CN	252

LM

LM13600N	252
LM1886	252
LM1889	253
LM2917N	253
LM301AN-8	253
LM308N	253
LM311N	253
LM319N	253
LM324N	254
LM339N	254
LM348N	254
LM358N	254
LM380	254

LM381	254
-----------------	-----

LM392	255
LM393N	255
LM3900N	255
LM3909N	255
LM3914N	255
LM3915N	255
LM396K	256
LM398H	256
LM6361N	256
LM723N	256
LM725CN	257
LM741-8	256
LM747	257
LM748	257
LM833	257

LT

LT1038	258
LT1080	258
LT1081	258
LT1083	258
LTC1043CN	258

M
MAX

MAX232	259
MAX233	259
MAX691CP	259

MC

MC1489	259
MC14411P	259
MC14C88	259
MC33174P	260
MC3340P	260
MC34119P	260
MC3423	260

MN

MN3004	260
MN3101	260

N
NE

NE531N	261
NE532N	261
NE5534N	261
NE5539N	261
NE555	261
NE556	262
NE565	262
NE571	262

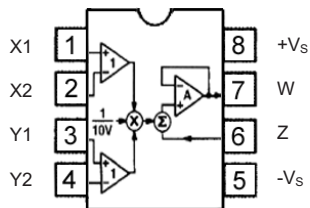

AD633JN

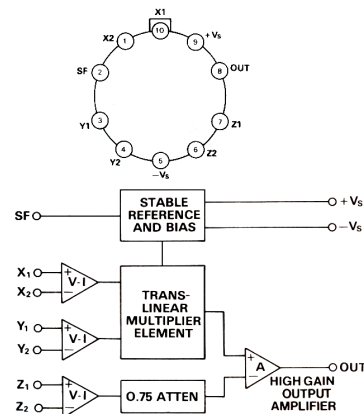

AD534JH

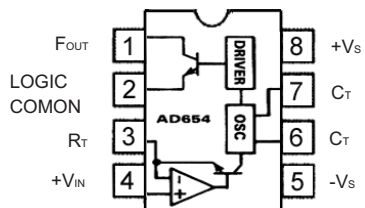

AD654JN

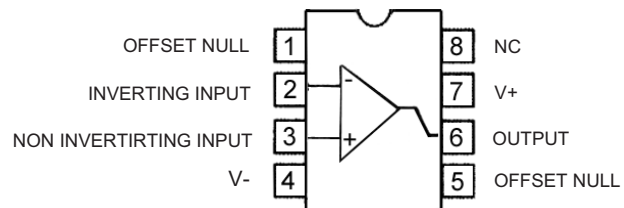

AD711JN

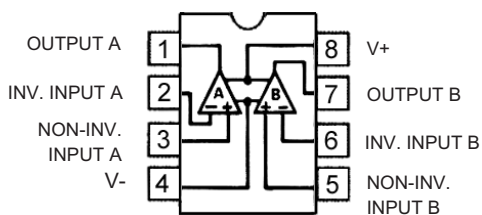

AD712JN

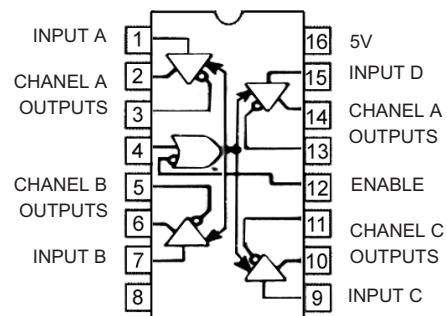

AM26LS31

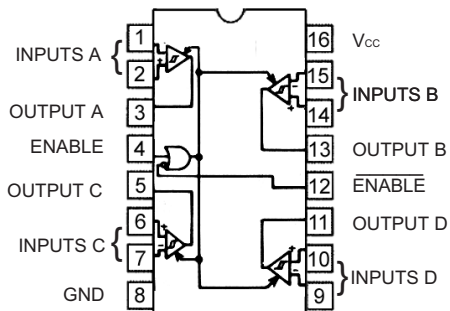

AM26LS32

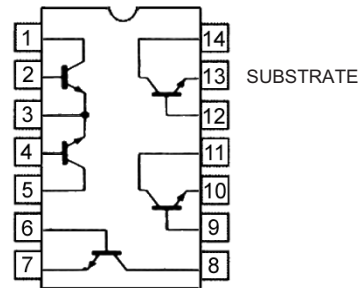

CA3046

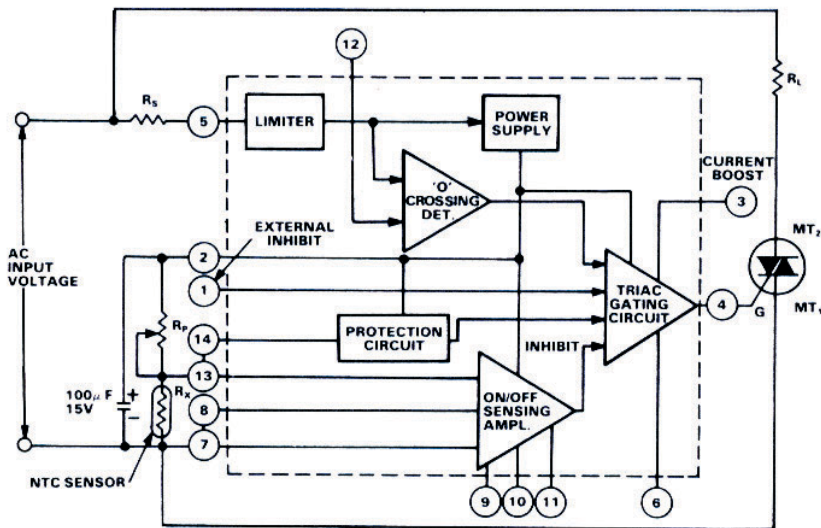

CA3059

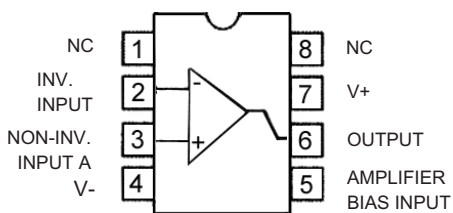

CA3080E

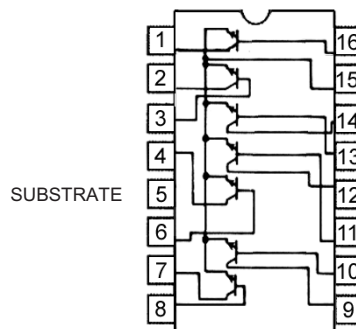

CA3081

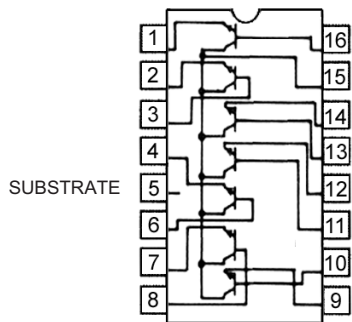

CA3082E

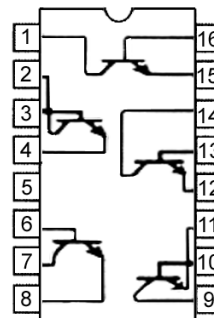

CA3083

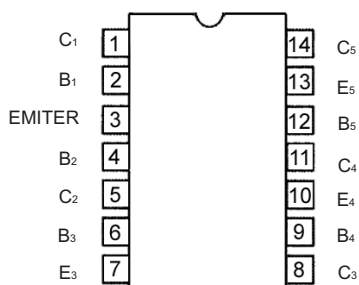

CA3086

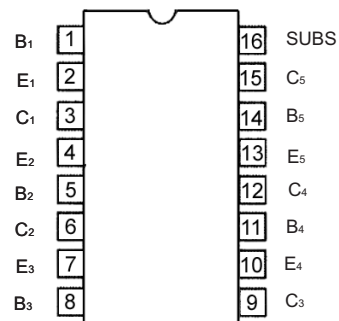

CA3096

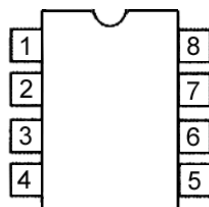

CA3130E

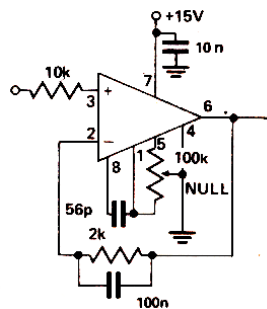

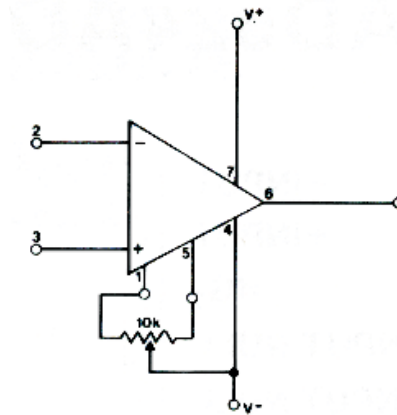
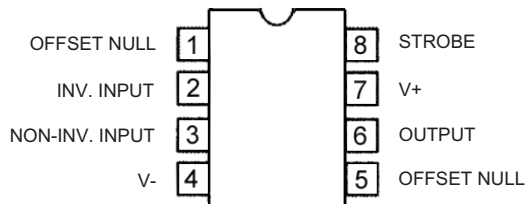

CA3140E

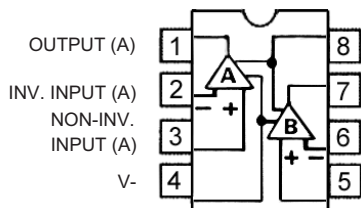

CA3240

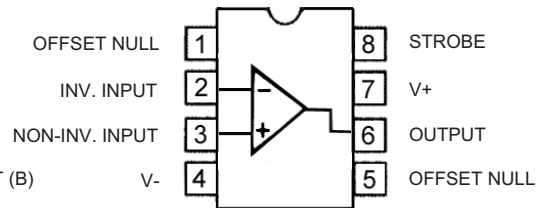

CA5160

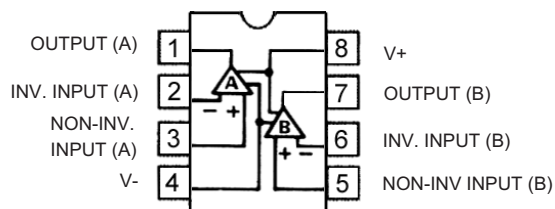

CA5260E

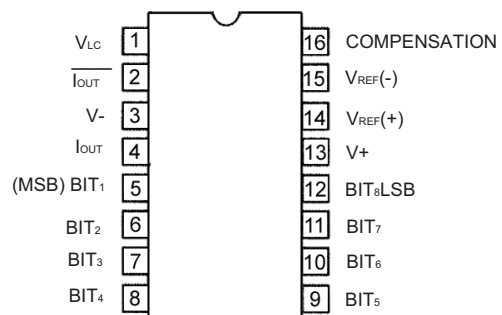

DAC0800LCN

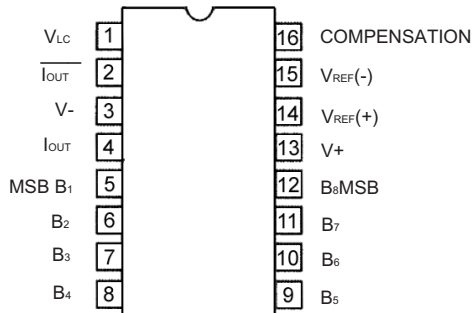

DAC08CP

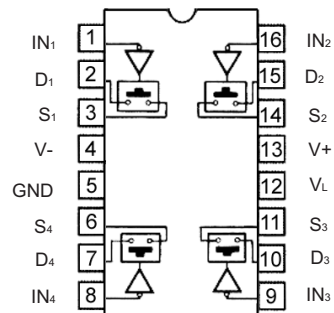

DG211CJ

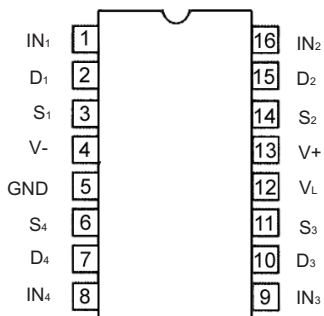

DG411

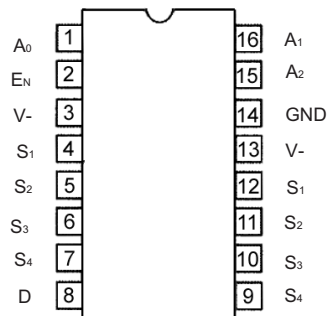

DG508ACJ

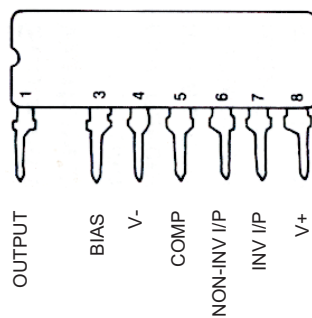

HA12017

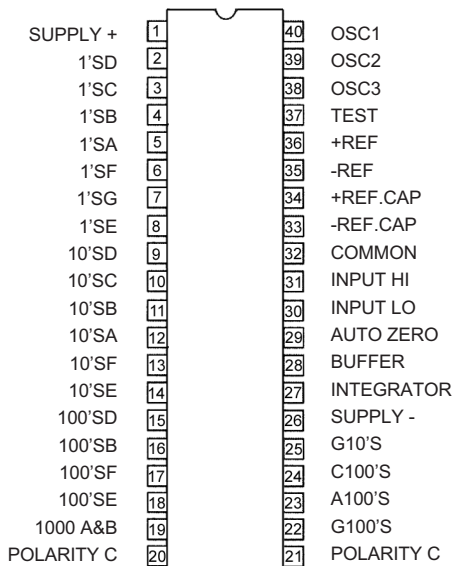

ICL7106CPL, ICL7107CPL, TSC7126CPL

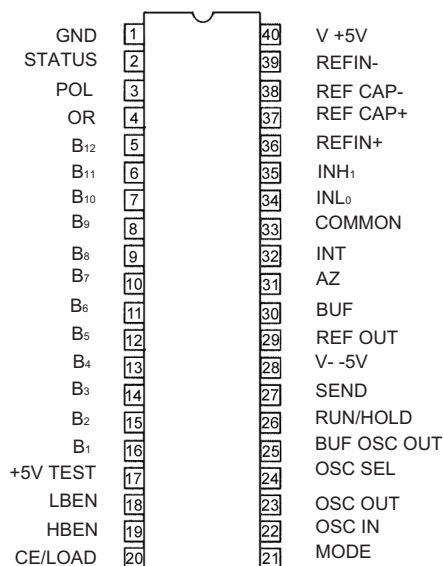

ICL7109CPL

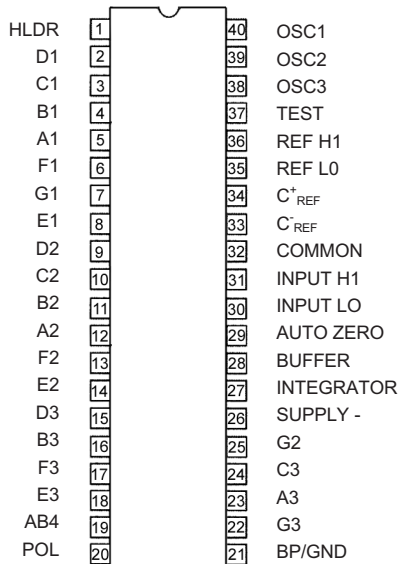

ICL7116CPL

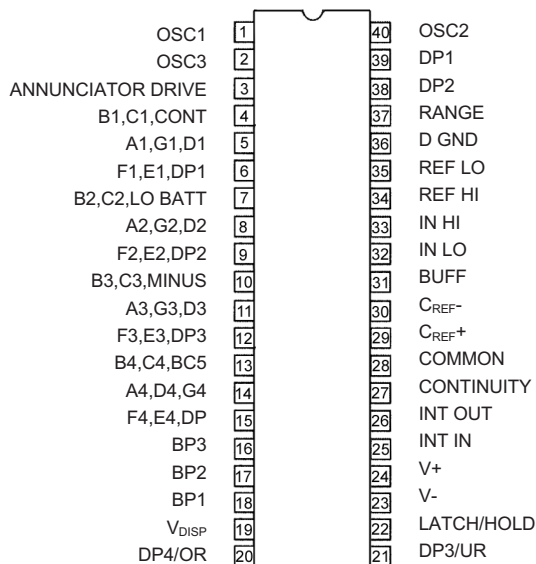

ICL7129CPL

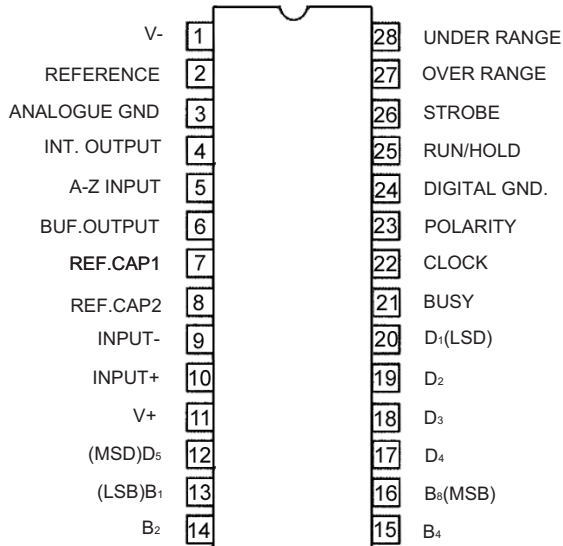

ICL7135CPL

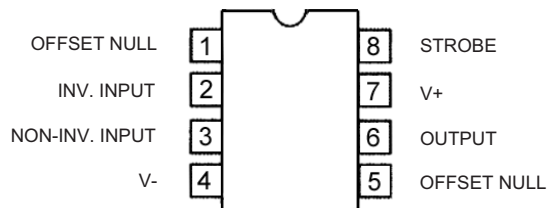

ICL7621DCPA

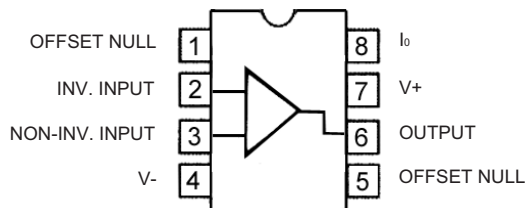

ICL7611DCPA

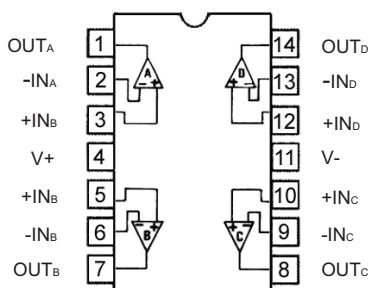
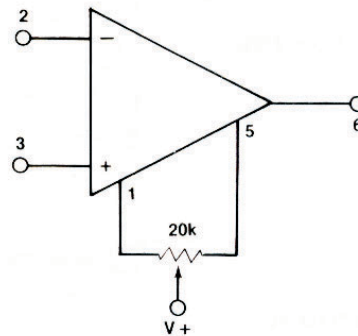

ICL7641ECPD

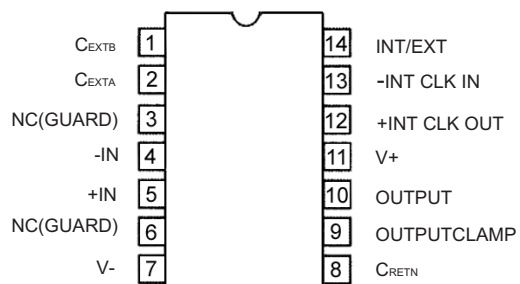

ICL7650CPD

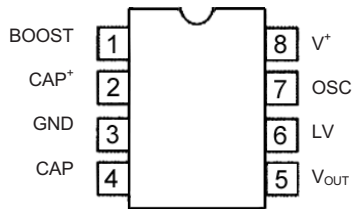

ICL7660CPA

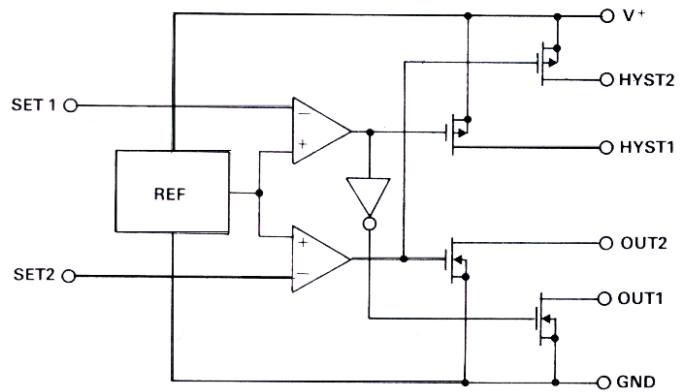
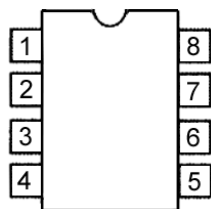

ICL7665CPA

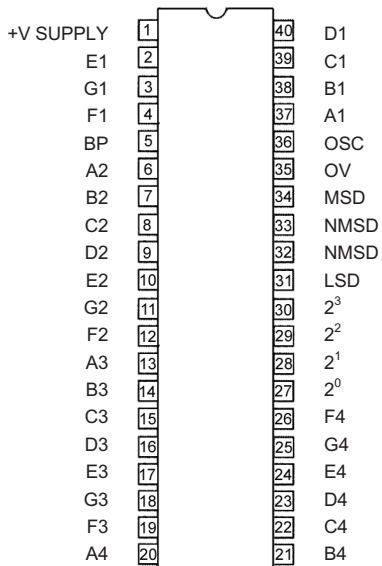

ICL7211AIPL

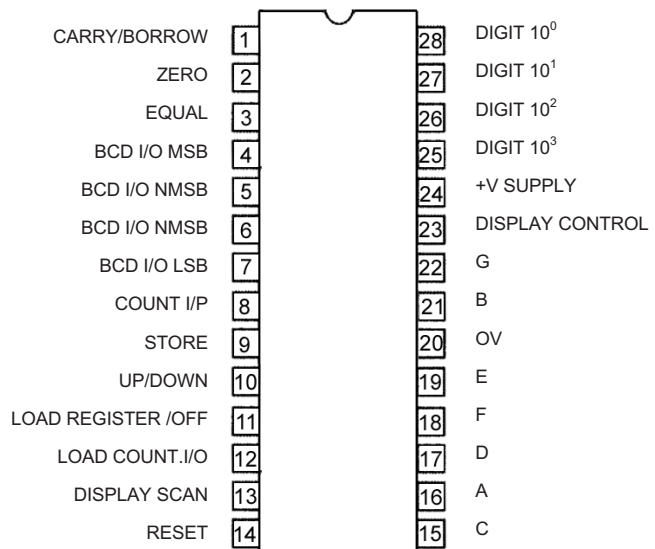

ICM7217AIJI

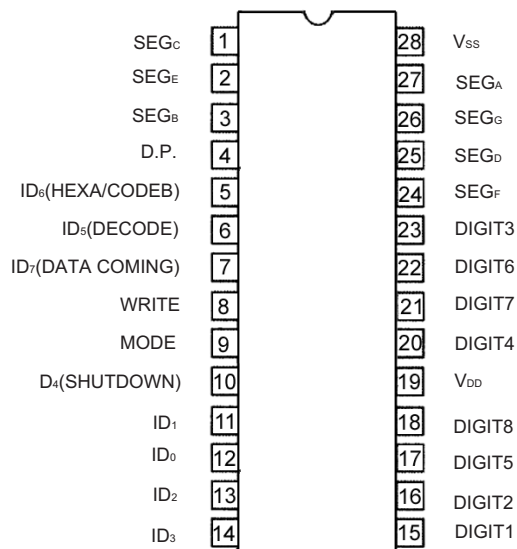

ICM7218AIJI

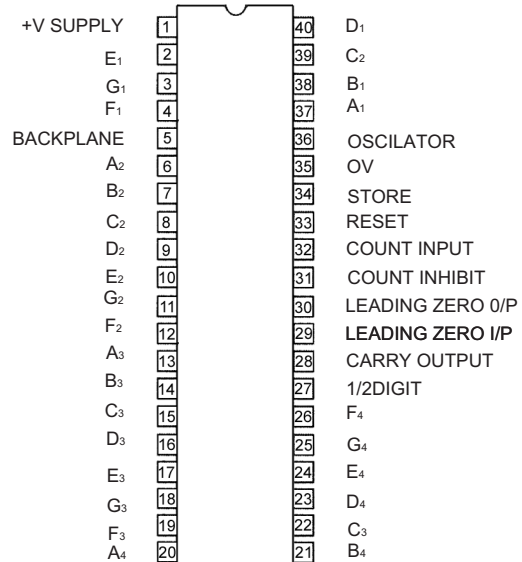

ICM7224IPL

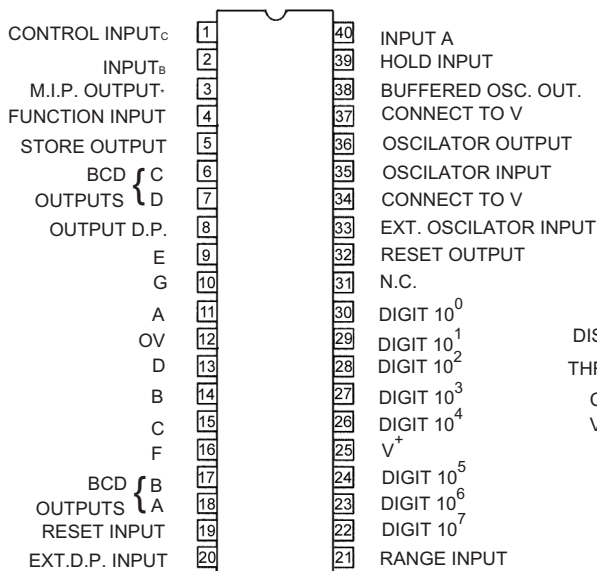

ICM7226AJL

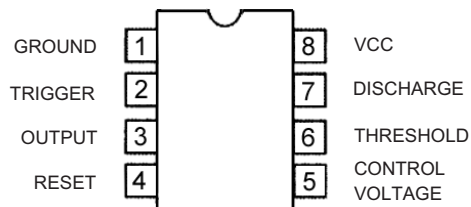

ICM7555IPA

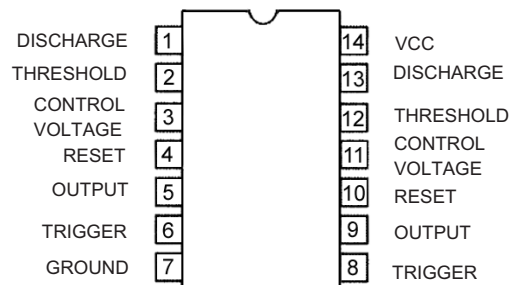

ICM7556IPD

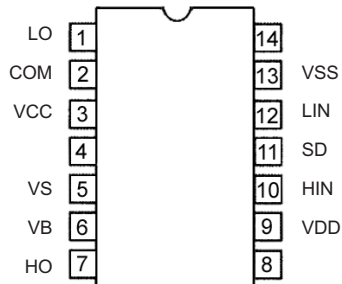

IR2110,IR2112,IR2113

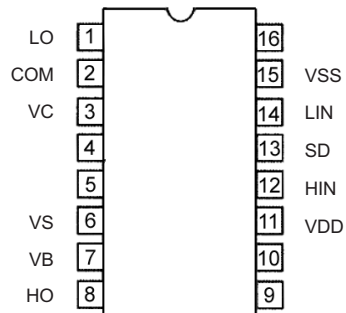

IR2110S-SMD,IR2112S-SMD

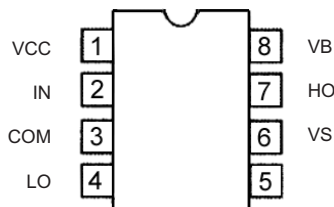

IR2111

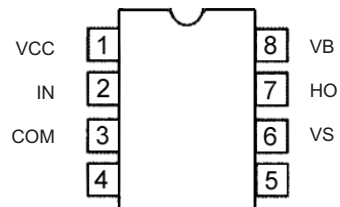

IR2117

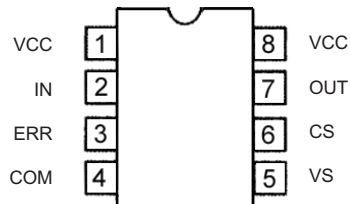

IR2121

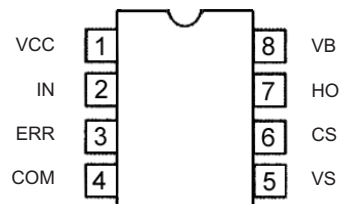

IR2125

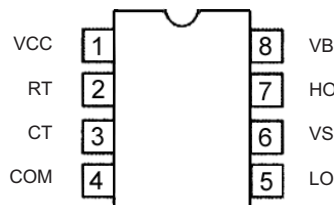

IR2151,IR2153,IR2155

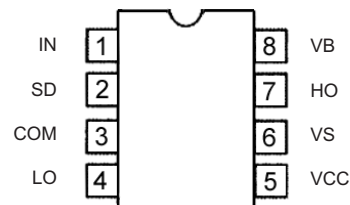

IR2184

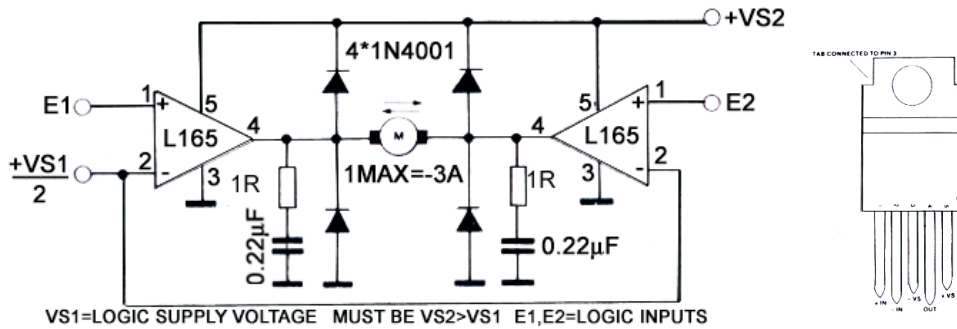

L165

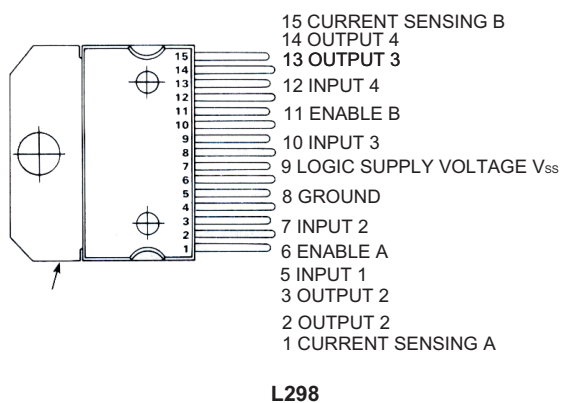
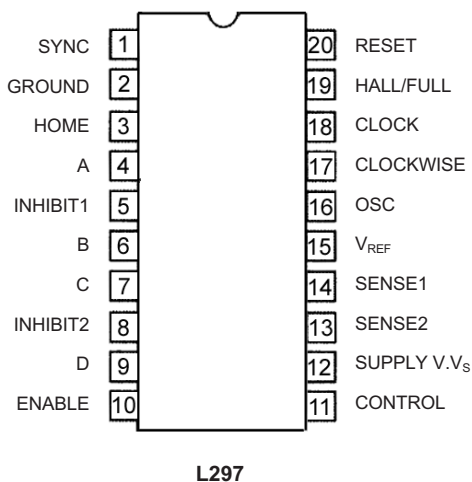
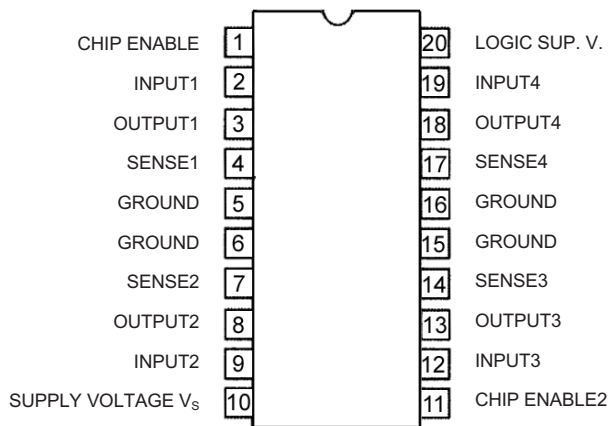
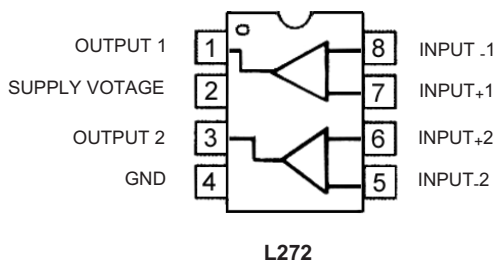

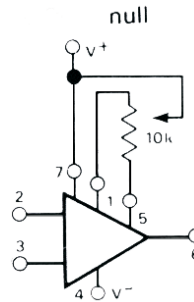
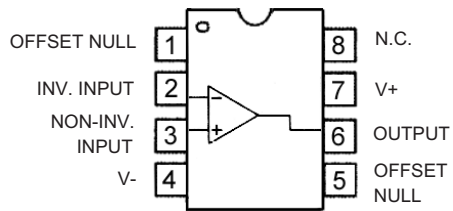

LF355N

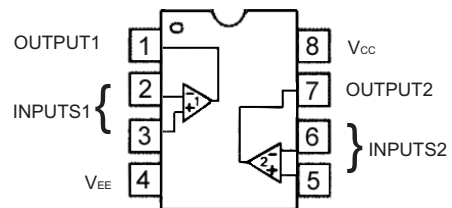
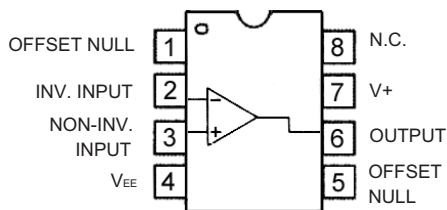

LF411CN

LF412CN

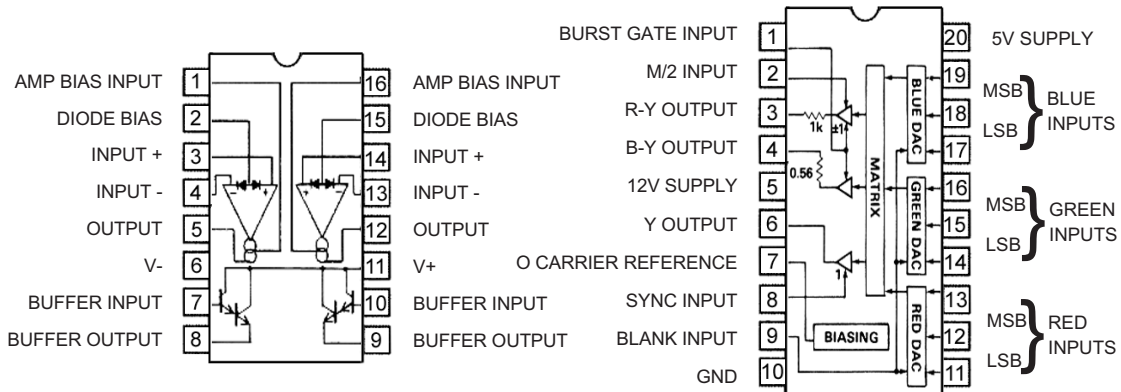

LM13600N

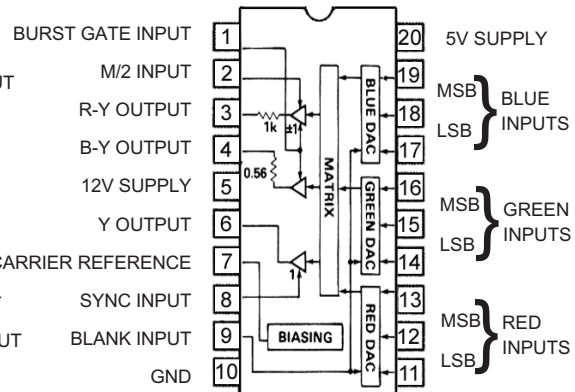

LM1886N

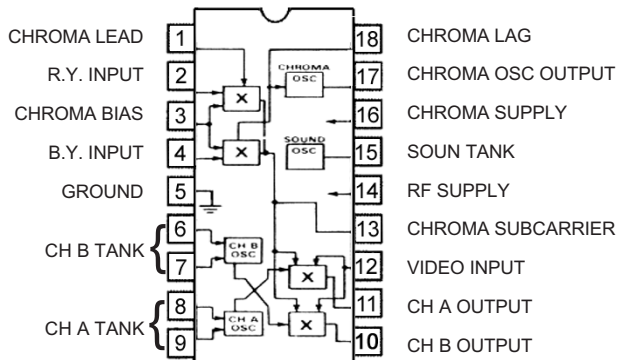

LM1889

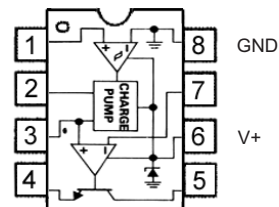

LM2917N

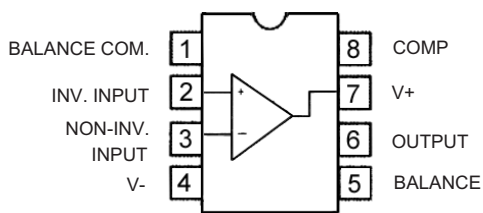

LM301AN

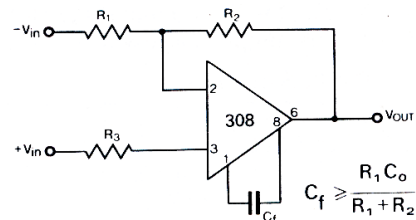

Standard compensation. $C_o = 30pF$

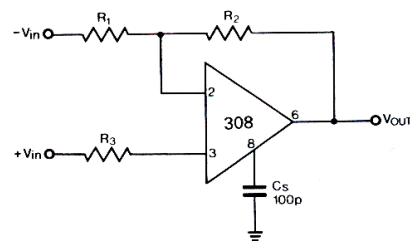

LM308N

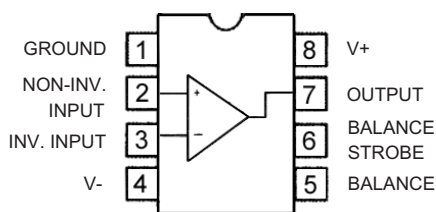

LM311N

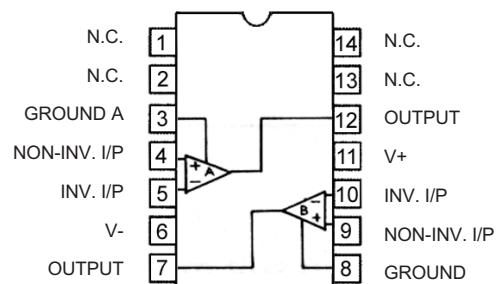

LM319N

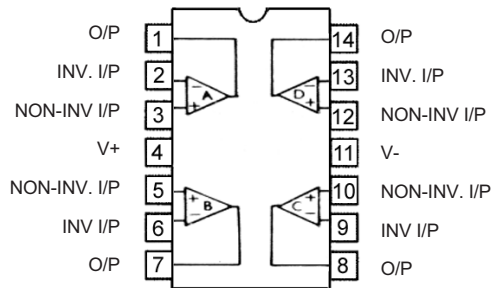

LM324N

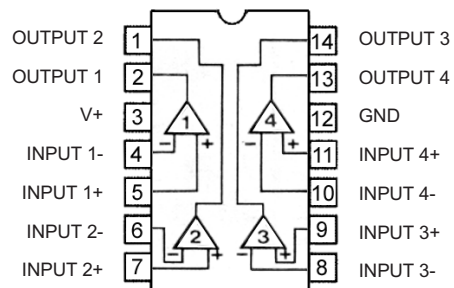

LM339N

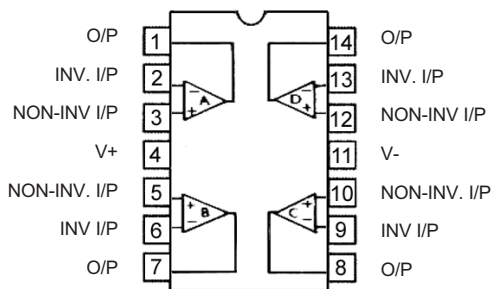

LM348N

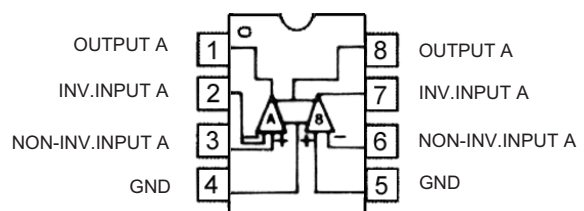

LM358N

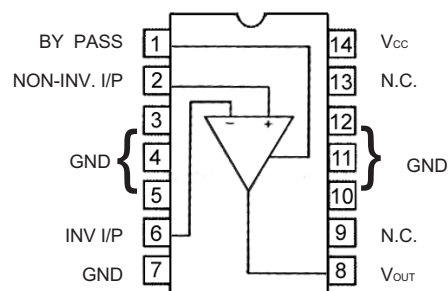

LM380N

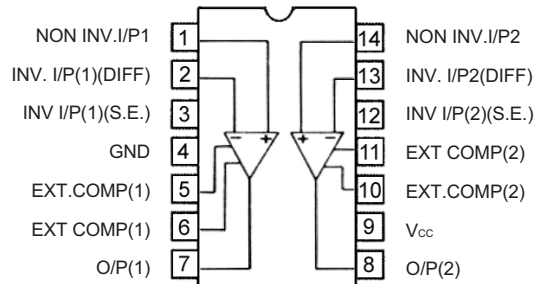

LM381N

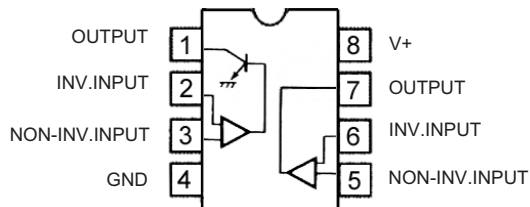

LM392

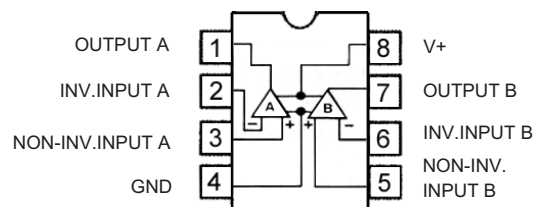

LM393N

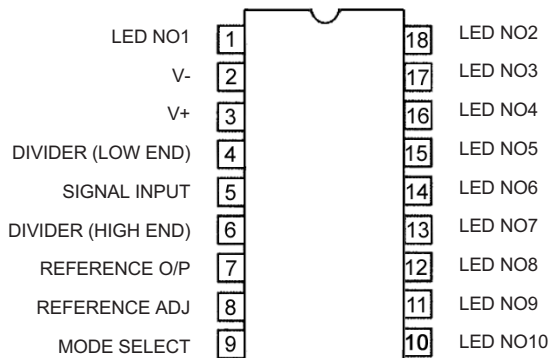

LM3914N-LM3915N

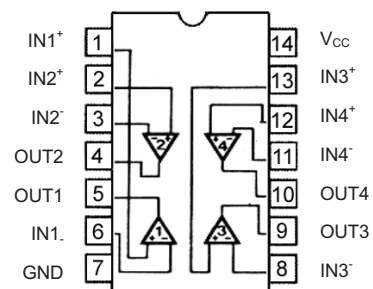

LM3900N

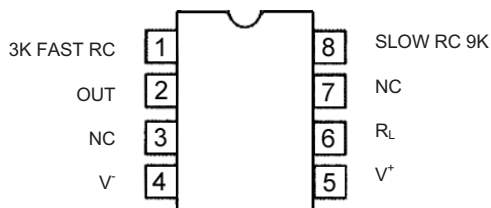

LM3909N

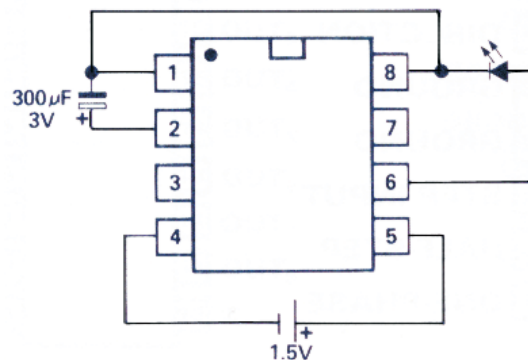

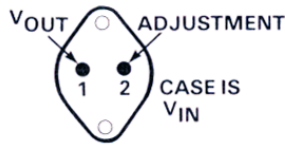
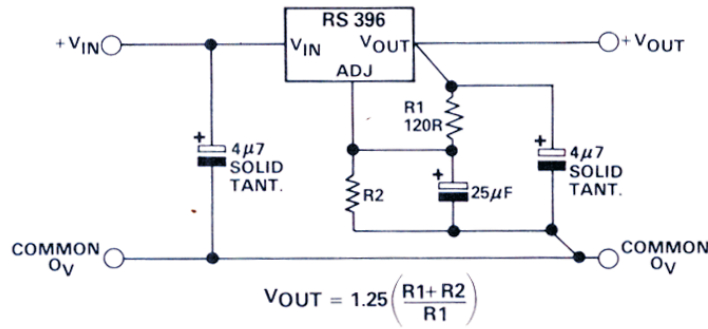

LM396K

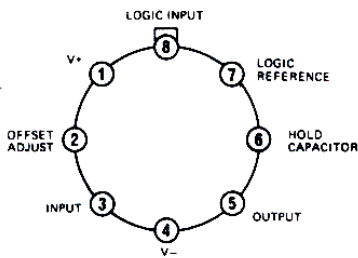

LM398H

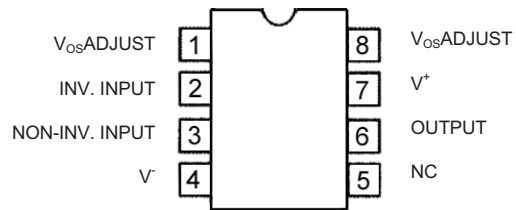

LM6361N

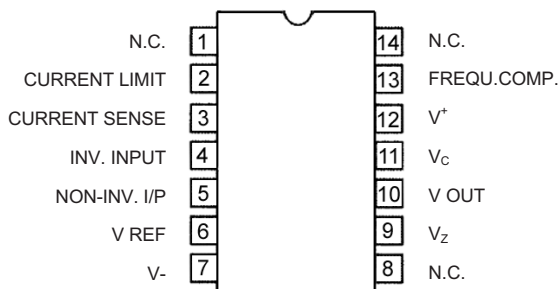

LM723

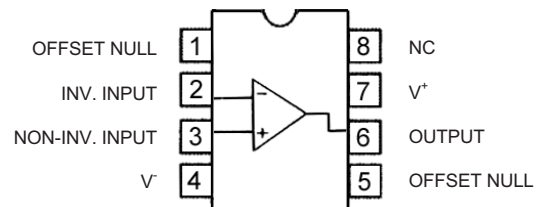

LM741-8

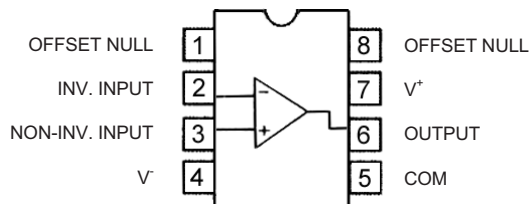

LM725CN

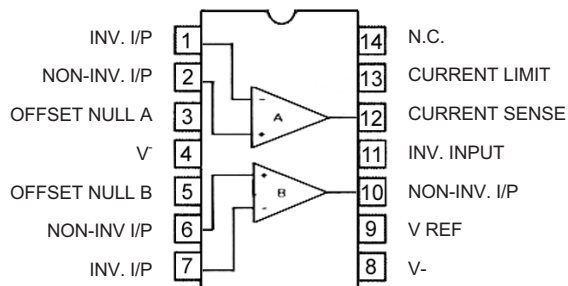
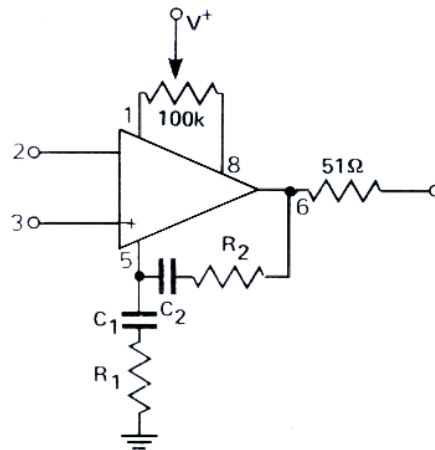

LM747

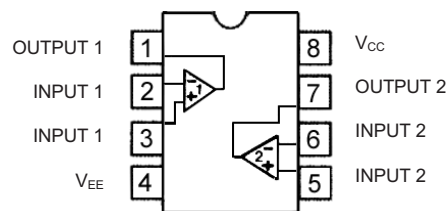

LM833N

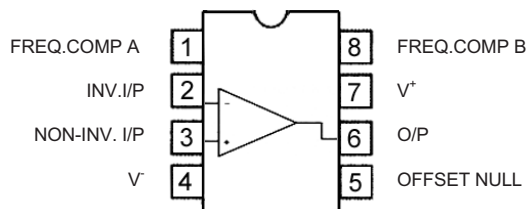

LM748

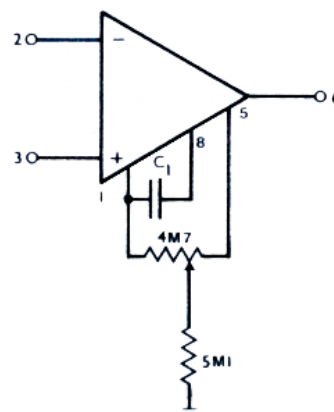

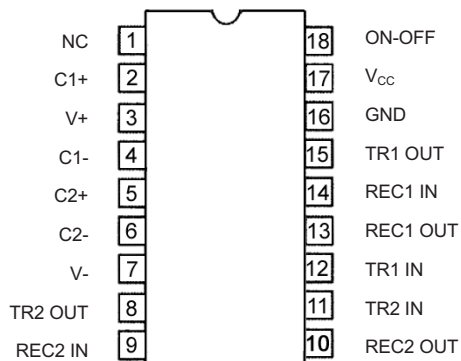

LT1080

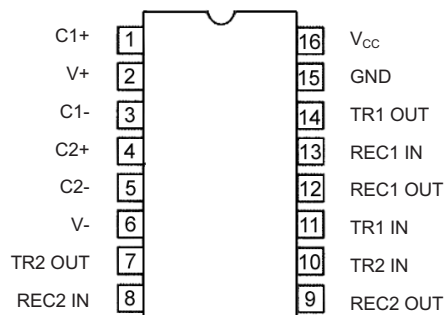

LT1081

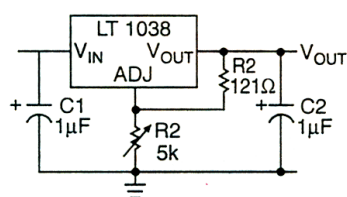

LT1038

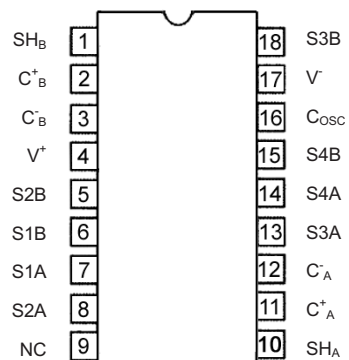

LTC1043CN

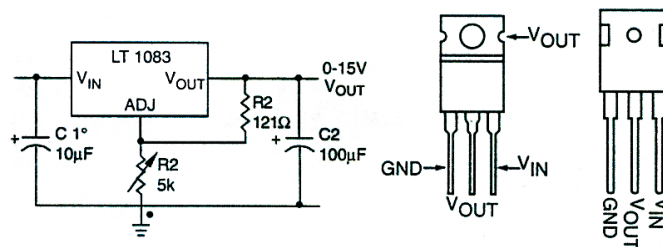

LT1083

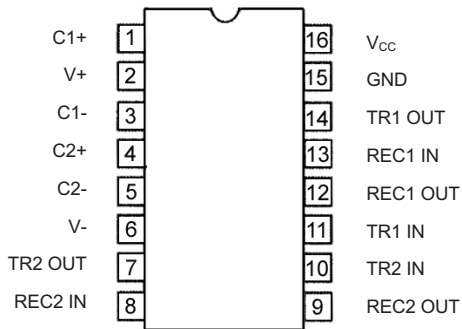

MAX232
ACPE, AEPE, CPE, EPE

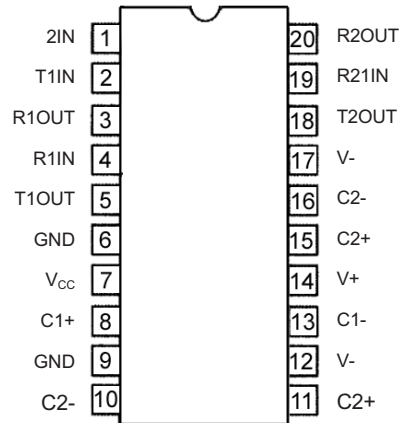

MAX233

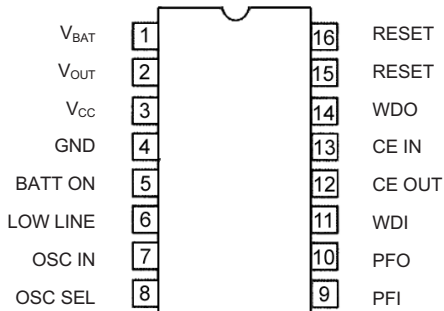

MAX691CPE

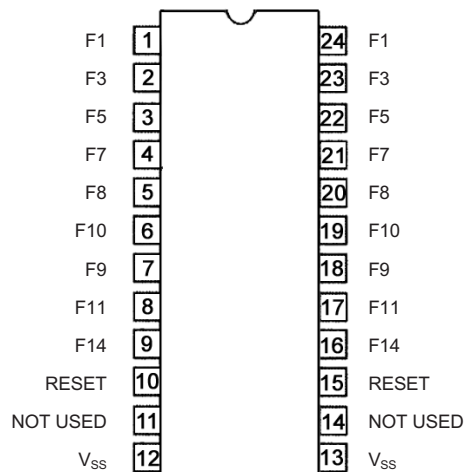

MC14411P

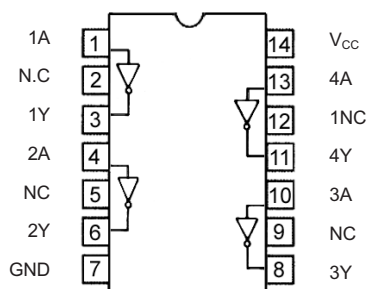

MC1489

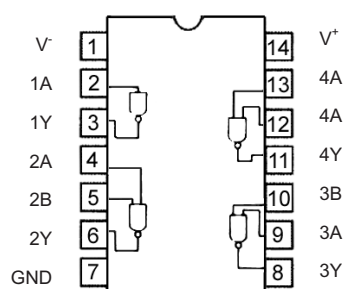

MC14C88

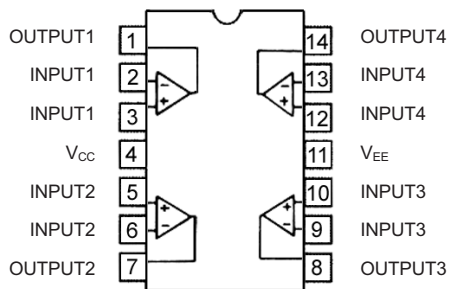

MC33174P

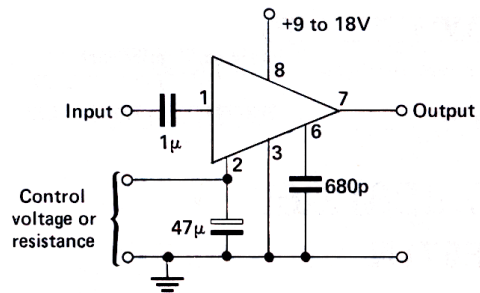

MN3340P

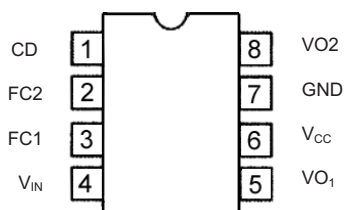

MC34119P

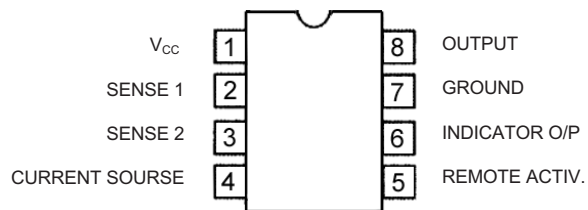

MC3423

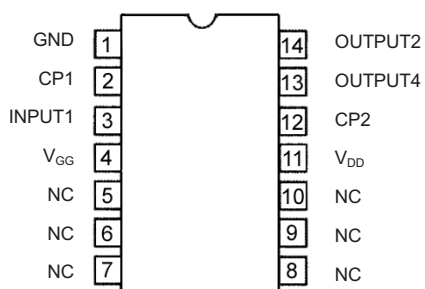

MN3004

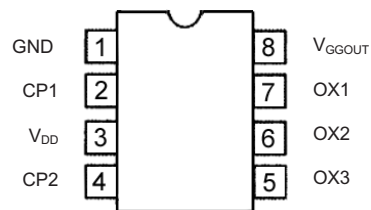

MN3101

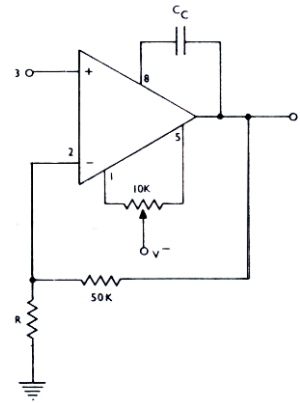
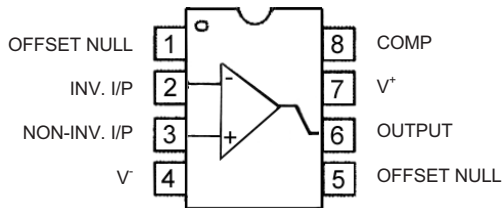

NE531N

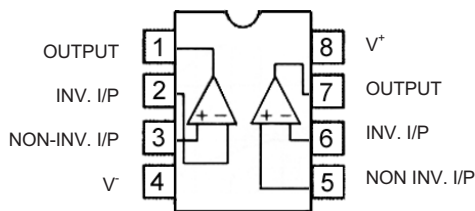

NE532N

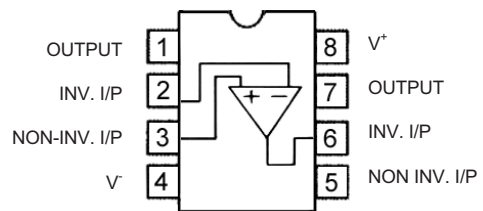

NE5534N

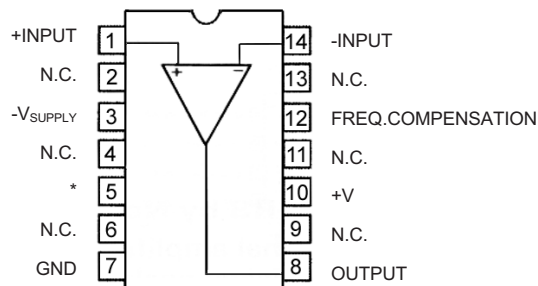

NE5539N

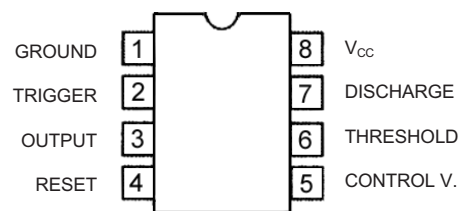

NE555

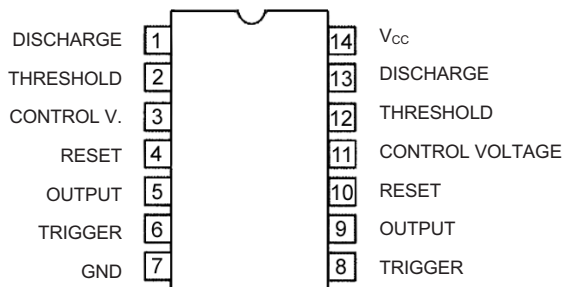

NE556

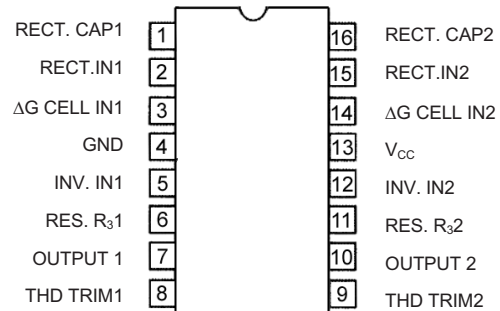

NE571

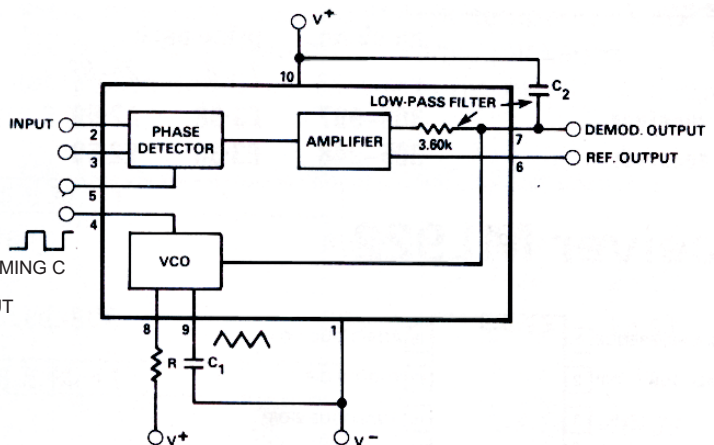
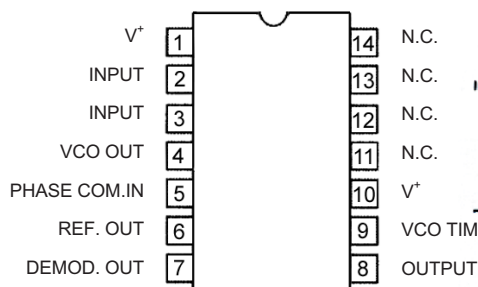

NE565

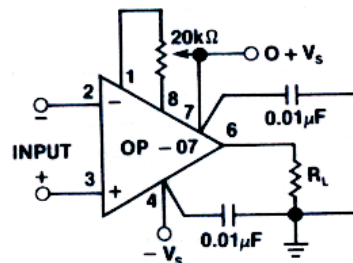
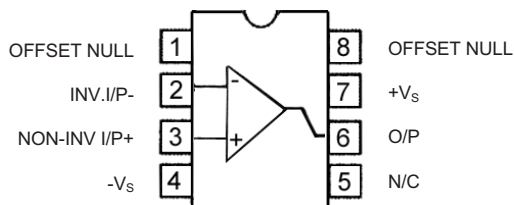

OP07CN

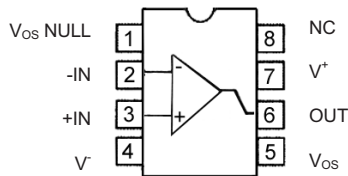

OP90GP

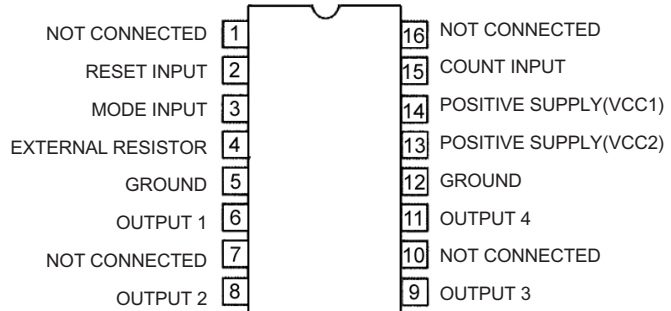

SAA1027

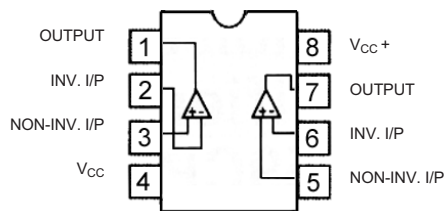

RC4558

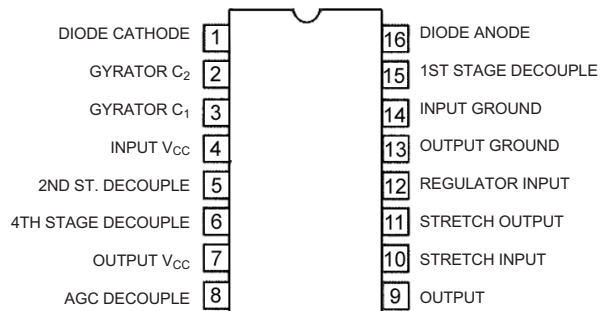

SL486

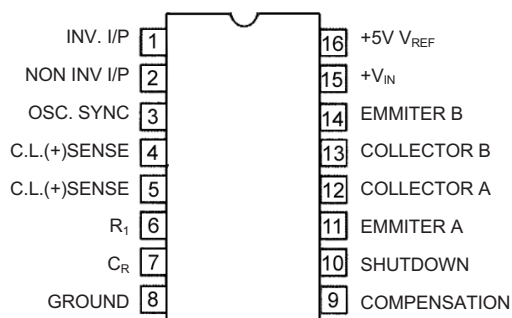

SG3524

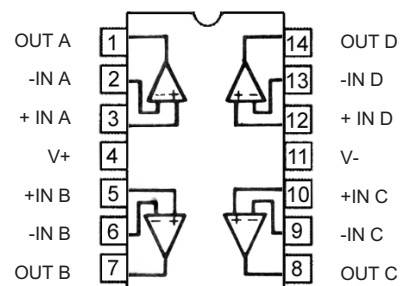

OP400GP

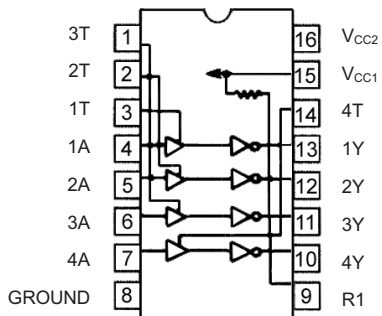

SN75154

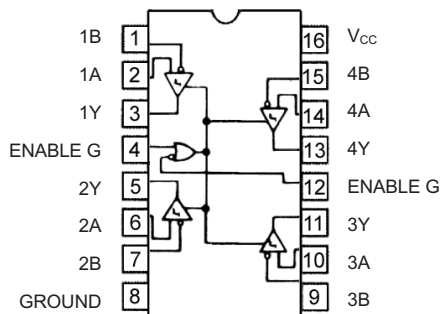
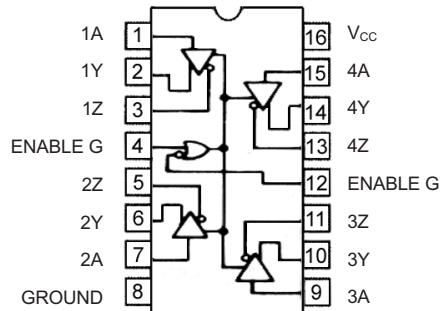

SN75173

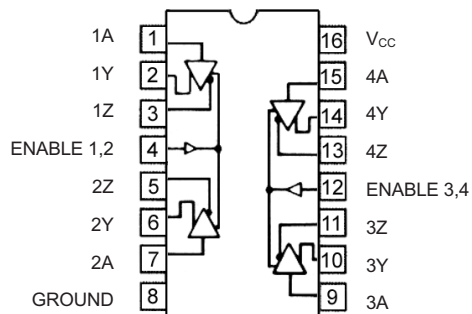

SN75174

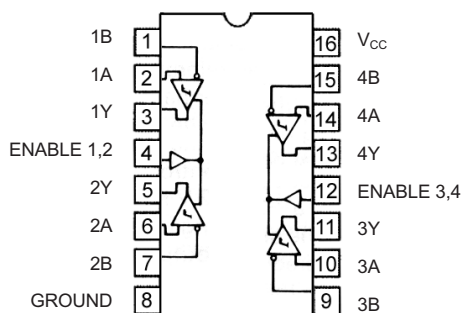

SN75175

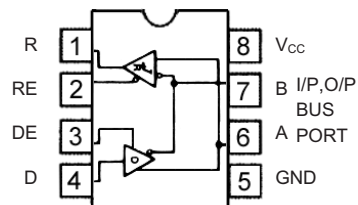

SN75176

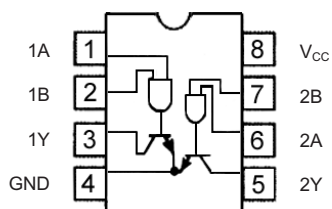

SN75452

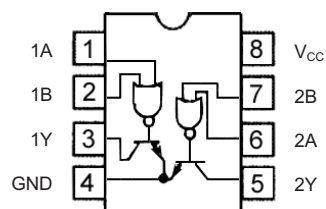

SN75453

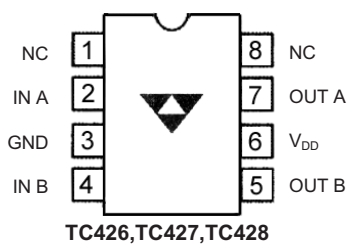

TC426, TC427, TC428

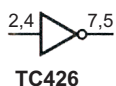

TC426

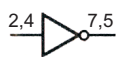

TC427

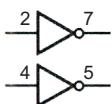

TC428

COMPLEMENTARY

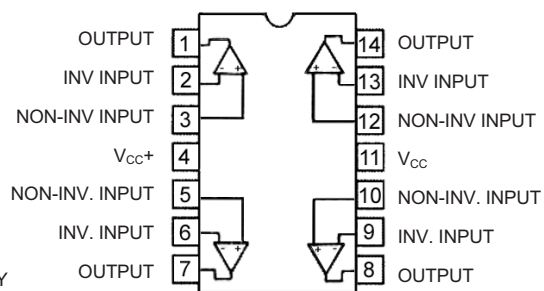

TL044

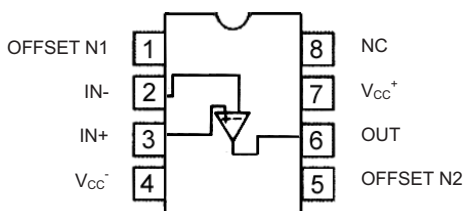

TL061

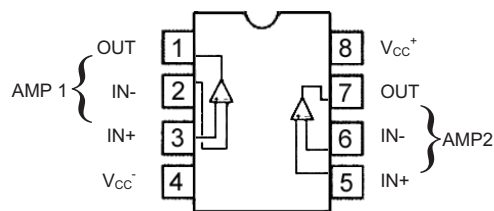

TL062

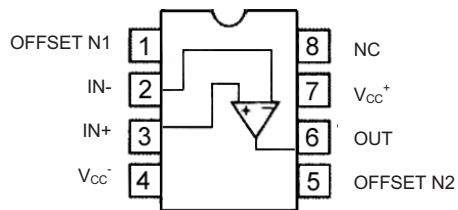

TL071

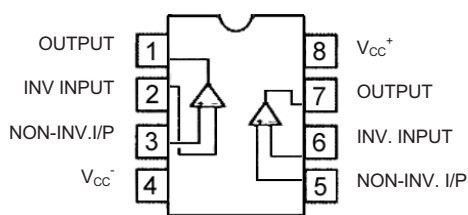
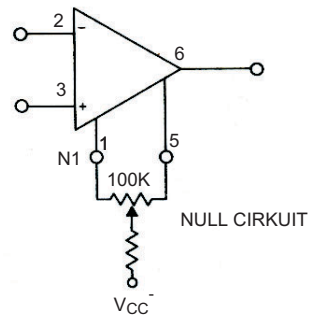

TL072

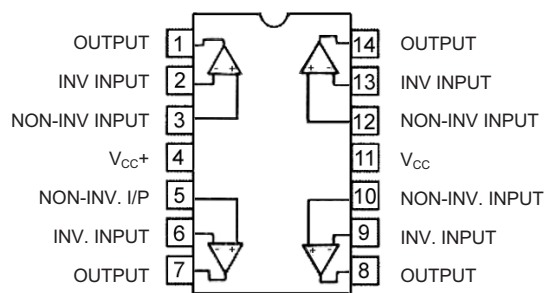

TL074

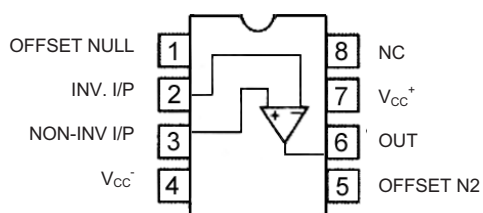

TL081

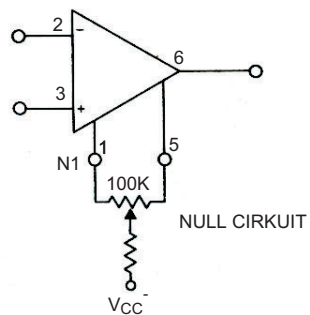

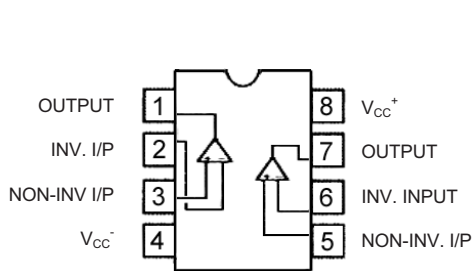

TL082CP

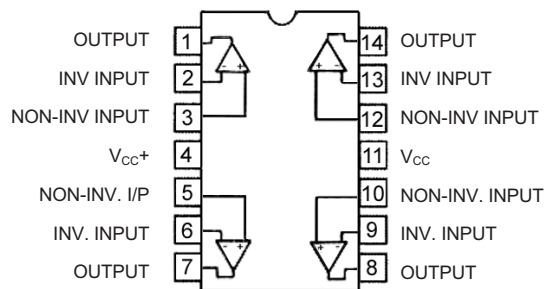

TL084CP

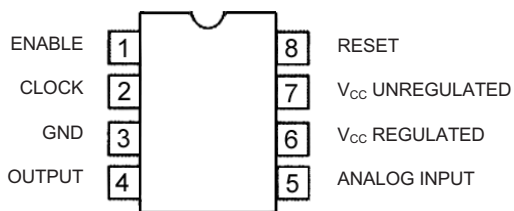

TL507CP

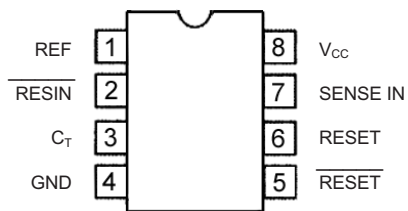

TL7705CP

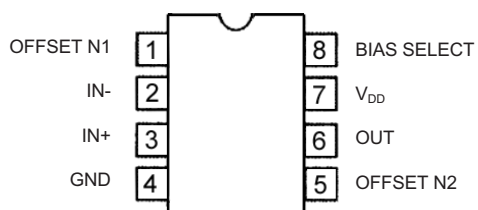

TLC271CP

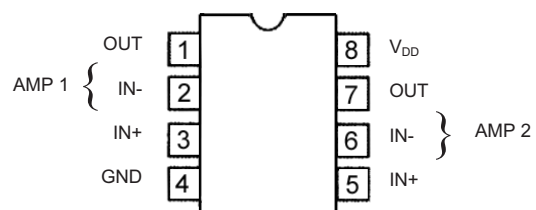

TLC272CP

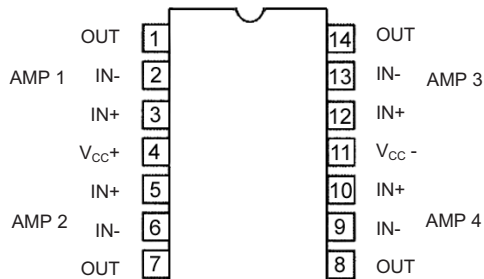

TLC273CP

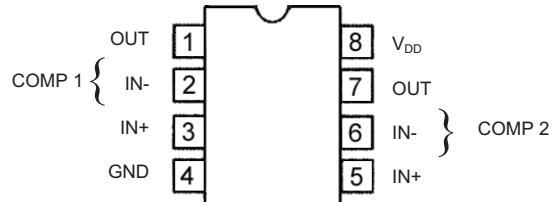

TLC372CP

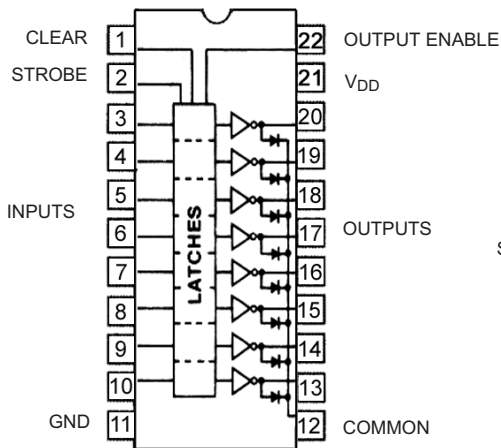

UCN5801

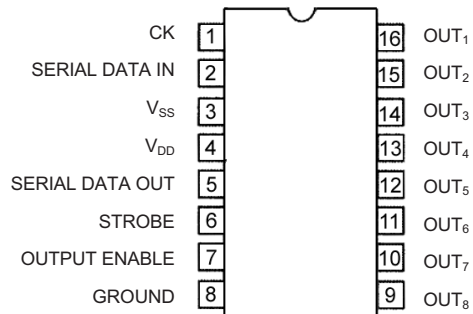

UCN5821

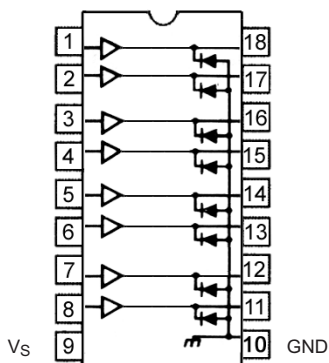

UDN2981

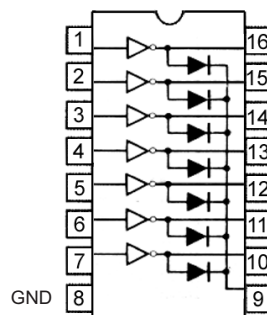

ULN2001

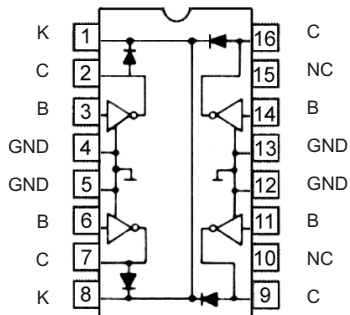

ULN2065

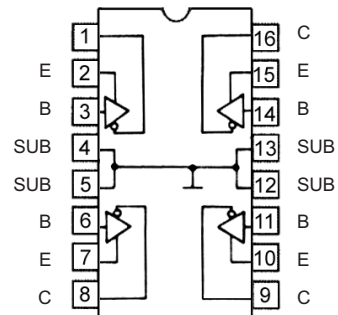

ULN2075

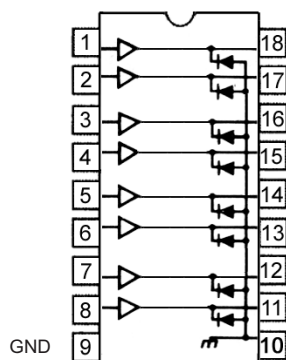

ULN2801

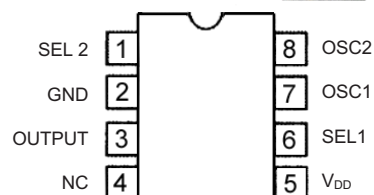
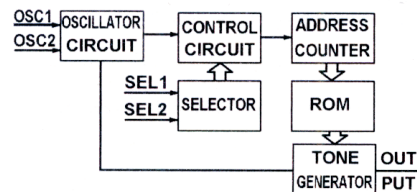

UM3561A

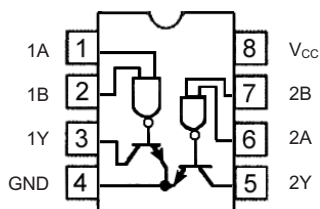

ULN75451

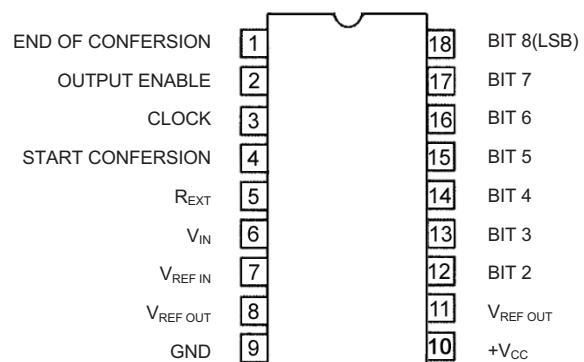

ZN427E