

WPO.7-12 12Volt 0.7Ah

Specifications

Nominal Voltage(V) 12V

Nominal Capacity

20 hour rate	(0.035A to 10.50V)	0.7Ah
10 hour rate	(0.067A to 10.50V)	0.665Ah
5 hour rate	(0.119A to 10.20V)	0.595Ah
1 C	(0.7A to 9.60V)	0.397Ah
3 C	(2.1A to 9.60V)	0.28Ah

Weight Approx. 400g(0.88Lbs.)

Internal Resistance (at 1KHz) Approx. 125 mΩ

Maximum Discharge Current for

5 seconds: 10.5A

Charging Methods at 25 (77)

Cycle use:

Charging Voltage 14.4 to 15.0V

Coefficient -5.0mv/ /cell

Maximum Charging Current : 0.21A

Standby use:

Float Charging Voltage 13.50 to 13.80V

Coefficient -3.0mv/ /cell

Operating Temperature Range

Charge -15 (5) to 40 (104)

Discharge -15 (5) to 50 (122)

Storage -15 (5) to 40 (104)

Charge Retention (shelf life) at 20 (68)

1 month 92%

3 month 90%

6 month 80%

Case Material ABS

(Option: UL94 HB & UL94 V-0 flame retardant)

Terminal WIRE



Dimensions

mm(inch)

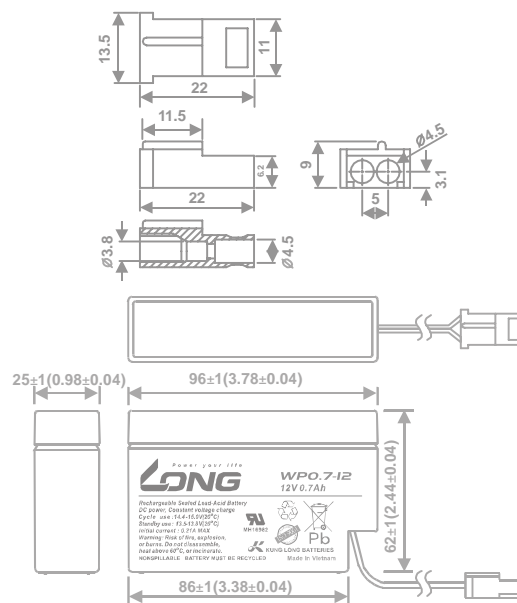

(v) FOR 12V BATTERY Discharge Time VS. Discharge Current (25)

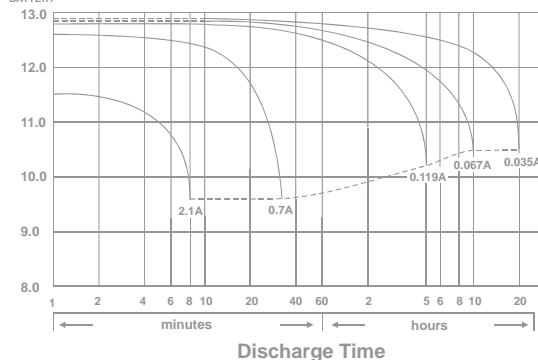

Effect of Temperature on Capacity 25 (77)

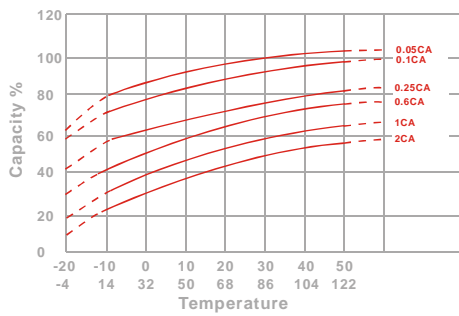

Capacity Retention Characteristic

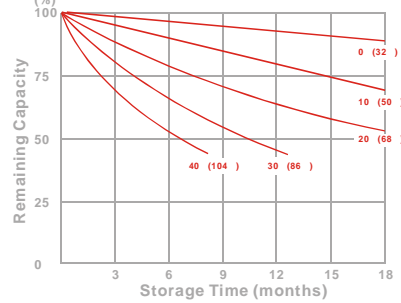

Trickle (or float) Service Life

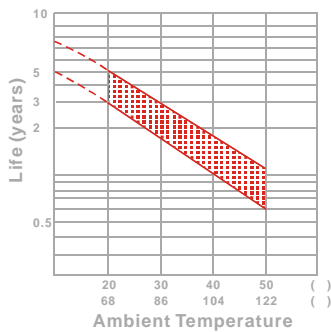

Cycle Service Life

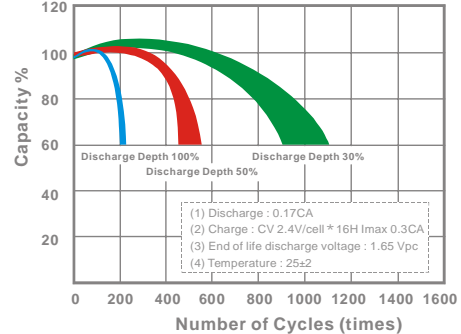

- PERFORMANCE DATA

Discharge Rates in Watts to Various End Voltages at 25 (77)

End Voltage		1.85V	1.80V	1.75V	1.70V	1.67V	1.65V	1.60V
Time								
5	min	20.2	24.8	27.2	29.1	29.8	30.7	31.8
10	min	15.9	18.4	20.3	21.8	22.3	22.9	23.6
15	min	13.8	15.2	16.1	16.7	16.9	17.2	17.5
30	min	8.05	8.53	8.89	9.16	9.25	9.36	9.49
60	min	4.92	5.19	5.38	5.54	5.60	5.67	5.76
120	min	2.91	3.12	3.27	3.39	3.44	3.49	3.56
180	min	2.02	2.19	2.31	2.40	2.43	2.47	2.52
240	min	1.69	1.81	1.89	1.96	1.98	2.01	2.04
300	min	1.48	1.55	1.60	1.64	1.65	1.66	1.68
600	min	0.788	0.816	0.851	0.864	0.869	0.875	0.881
1200	min	0.420	0.432	0.441	0.448	0.450	0.452	0.455

- Discharge Rates in Amperes to Various End Voltages at 25 (77)

End Voltage		1.85V	1.80V	1.75V	1.70V	1.67V	1.65V	1.60V
Time								
5	min	1.82	2.31	2.62	2.86	2.94	3.03	3.14
10	min	1.38	1.61	1.79	1.94	1.99	2.05	2.12
15	min	1.14	1.30	1.41	1.48	1.50	1.53	1.56
30	min	0.638	0.703	0.755	0.801	0.816	0.833	0.852
60	min	0.424	0.447	0.462	0.475	0.480	0.486	0.493
120	min	0.245	0.260	0.271	0.282	0.286	0.290	0.296
180	min	0.169	0.181	0.190	0.198	0.201	0.205	0.209
240	min	0.137	0.145	0.151	0.156	0.161	0.164	0.167
300	min	0.118	0.124	0.129	0.133	0.134	0.136	0.138
600	min	0.062	0.065	0.067	0.069	0.070	0.071	0.072
1200	min	0.0345	0.0352	0.0358	0.0363	0.0365	0.0368	0.0371

All data on the spec. sheet is an average value:

The tolerance range : X<6min(+15%~-15%), 6min X<10min(+12%~-12%), 10min X < 60min(+8%~-8%), X 60min(+5%~-5%)