

MM5837 Digital Noise Source

General Description

The MM5837 digital noise source is an MOS pseudo-random sequence generator, designed to produce a broadband white noise signal for audio applications. Unlike traditional semiconductor junction noise sources, the MM5837 provides very uniform noise quality and output amplitude. The shift register starts at a random non-zero state when power is applied. The circuit is packaged in an 8-lead plastic DIP.

Features

- Uniform noise quality
- Uniform noise amplitude

- Eliminates noise preamps
- Self-contained oscillator
- Single component insertion

Applications

- Electronic musical rhythm instrument sound generators
- Music synthesizer white and pink noise generators
- Room acoustics testing/equalization

Logic and Connection Diagrams

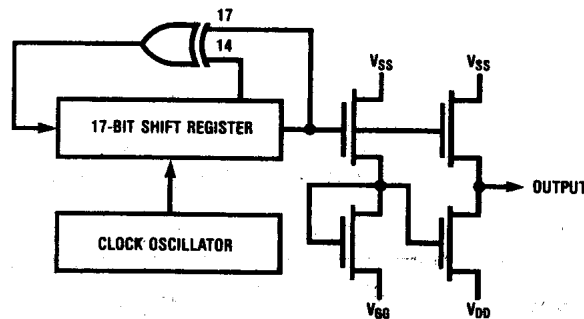

Dual-In-Line Package

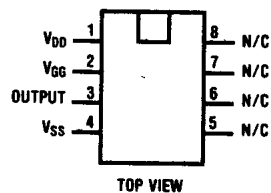

Order Number MM5837N
See Package 17

MM5837

Absolute Maximum Ratings

Optional Gate Supply Voltage, V_{GG}	$V_{SS} - 33V$ to $V_{SS} + 0.3V$
Logic Supply Voltage, V_{DD}	$V_{SS} - 25V$ to $V_{SS} + 0.3V$
Storage Temperature, T_S	$-55^{\circ}C$ to $+100^{\circ}C$
Operating Temperature, T_A	$0^{\circ}C$ to $+70^{\circ}C$
Lead Temperature (Soldering, 10 seconds)	$300^{\circ}C$

Electrical Characteristics

T_A within operating range, $V_{SS} = 0V$, $V_{DD} = -14V \pm 1.0V$, $V_{GG} = -27V, \pm 2V$ unless otherwise noted

Parameter	Conditions	Min.	Typ.	Max.	Units
Output (Loaded $20k\Omega$ to V_{SS} and $20k\Omega$ to V_{DD})	$T_A = 25^{\circ}C$ $V_{GG} = -14V \pm 1V$	$V_{SS} - 1.5$		V_{SS}	V
Logical "1" Level		V_{DD}		$V_{DD} + 1.5$	V
Logical "0" Level		V_{DD}		$V_{DD} + 3.5$	V
Supply Currents	No Output Load				
I_{DD}		3		8	mA
I_{GG}				7	mA
Half Power Point		24		56	kHz
Cycle Time		1.1		2.4	Sec.

Typical Application

